

MODULAR PROTECTIVE SCREENS

- STAINLESS STEEL FRAMING
- MOBILE OR STATIONARY

- LEXAN SHIELDS
- CUSTOM SIZING AVAILABLE

Model Series: HMPS-XX

APPLICATION:

- Protective screening for front line reception, security guards, triage personnel

SPECIFICATIONS:

- Stainless steel tubular frame structure; Type 304 # 4 finish
- Combination welded/bolted structure
- Lexan material utilized for screens – heavy duty
- Plexi glass also available
- Equipped with casters or stationary feet
- Talk through panel component available
- Available in multiple panel configurations
- Manufactured to suit client specific application

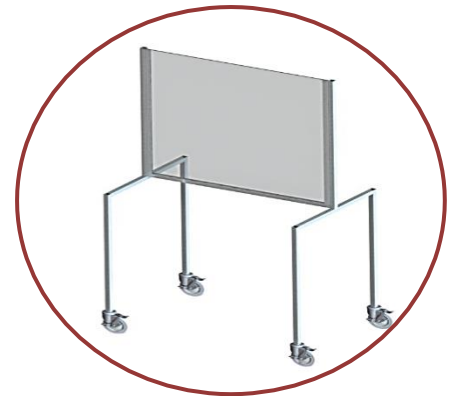
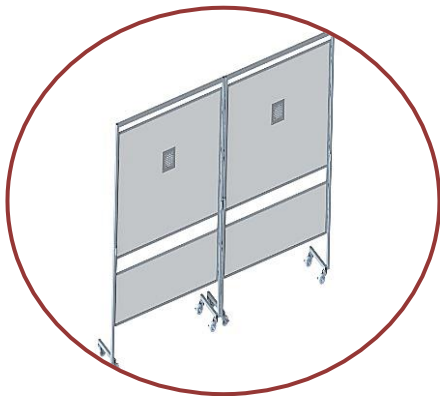

Contact the Factory direct for pricing and expedited delivery

© Copyright 2020 Hatch Industries Limited

CANADA/USA TOLL FREE: 1-800-387-6969 FAX: 1-519-822-8365 www.hatchindustries.com